

GP SG

**MotoGP Technology
Fantastic Precision
Fully Computerized
Amazing Performance
Proven Championship Winner
Nordic BoTT 2010, 2011. PRO
Superbike n.o. 2, 2010. n.o. 1
2011.**



South Coast Engineering AB
Mårten Jöns Väg 6
274 56 ABBEKÅS
SWEDEN

Cordona Strain Gauge/Loadcell GP Switch Quickshifter, GP SG type 1.4

No movable parts, i.e. super durable, designed for MotoGP, WSBK and Endurance racing use. Fully adaptive sensing of either push or pull linkages, will automatically learn which way to up shift. Preload adjustable 1 kg to 40 kg, force needed for activation. Temperature, vibration and creep adjustments done automatically with high precision by 20Mhz processor for an absolute stable up shift signal in all riding conditions. User friendly preload settings done on miniature digital LED panel; located 1m from sensor. Can be set up to close a loop @ up shift or to open a loop. Dimensions: 45mm long, 14mm diameter. Output: closed or open loop digital signal at up shift. CNC machined with super high precision from stainless steel. Sensor has Magic Threads, left and right hands treads can be used in both openings. Up gradeable to 1.4., dot denotes adjustable killtime, suitable for Honda HRC, and Dyna 2-4000. Absolutely Waterproof. Sensor available as spare part, will recalibrate new sensor automatically at power up. Prototype tested to 603 000 activations with 45 kg force, about 12 years of use. Designed and made with pride in Sweden

Installation

Tools needed: 8mm and 10mm spanner, (Hacksaw, 5 mm drill and m6 tap).

Remove and measure stock shift rod; cut included shiftrod to correct length and tap M6 if needed, cut a short piece at a time and drill beforehand so the drillbit is centered. Install sensor and rod with uniball links on both ends, most bikes have uniballs stock, check that the shiftrod

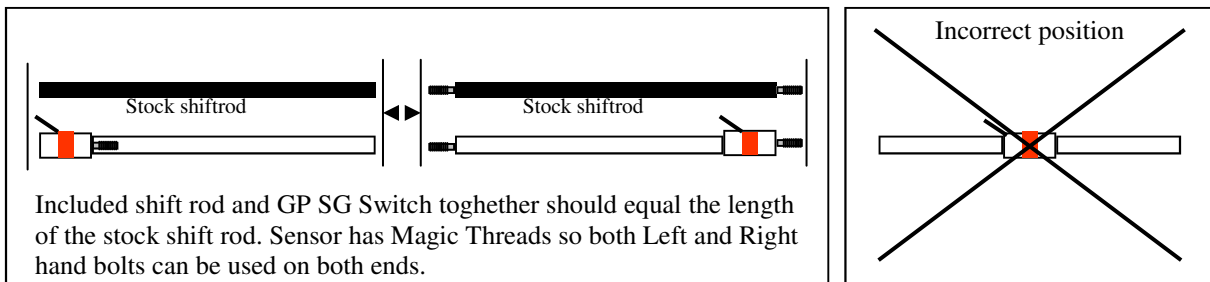

does not rub or touch anything, could impair sensing. **Do not bottom out the studs hard in the GP SG, could impair sensing. Make sure wire has a slight bend/loop so it does not tighten up and pull at the sensor during up or down shift.** Warranty does not cover ripped out wires.

Connect **Green** wire to ignition switched + 12v and **Brown and White together** to earth/ground, frame or battery (cordona PQ8 black). Connect **Yellow** (up shift signal) to quickshift device, (Cordona PQ8 wire pink).

For Yamaha YEC, Powcommander 3 USB, Powercommander 5, Honda HRC, Dyna 2000, see pp3.

Initial set up

1. Switch ON ignition, the GP SG panel should light up if right button is pressed. Switch OFF ignition again and back ON while pressing both buttons (some bikes will have power on for 2 minutes after ignition is switched off, if so, disconnect GP SG and plug back in while holding both buttons). Display **flashes up-up-up-up**.

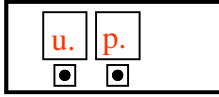

2. Move shifter pedal and do a simulated **up shift from 2nd to 3rd gear** and hold the pedal for about 2 seconds; display goes black.
3. Now you have successfully completed set up for your bike's direction of up shift. A new initial Set up can be done at any time in case you change bike or shift pattern.
4. Press right button and display will show up shift **default "15" (kg)**, suitable for most bikes to get going.
5. **Test ride bike.** Start at low rpm and work your way up the rev range. Make sure to really move the shifter pedal swift and with force, don't try to caress the next gear in.

Preload (kg) change/ programming

99% of our customers use 10-12kg.

6. With ignition on, **Engine off**, shift to 6th gear and try to select a 7th gear (to avoid nasty noise from the gearbox). Shiftlever should move through the spring load in gearbox until gear resistance is felt, now activation of the up shift LED dot should be seen briefly on the panel.
7. Start the engine in 6th gear, **WARNING, make sure clutch lever is pulled all the way in to the handle bar, secure clutch lever with 2 zip ties and keep one hand on it so your bike does not take off out of control, creating a very hazardous situation.** Raise rpm above ON rpm set on quickshift device; do upshifts to 7th gear and make sure rpm dips briefly and then pick right back up again.
8. To change **up shift preload**, can be set 1-40 (kg). **1. press right button, 2. while "15" is showing, hold both buttons until 15 starts to flash, 3. change value up or down, 4. hold both buttons until the new value stops flashing, preload change completed.**

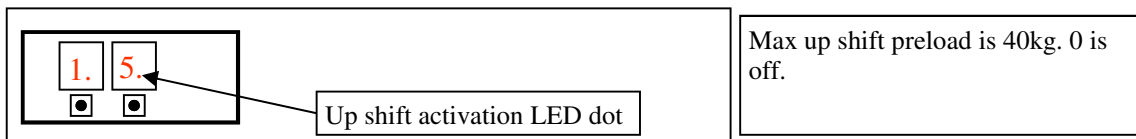

9. **Change in between commonly closed circuit and open circuit;** see PC5 instr on pp3.

Yamaha YEC

White and Yellow to YEC up shift signal port, yamaha uses a 5v signal and with White and Yellow GP SG wires the YEC 5v output will go through GP SG and won't be connected to ground, 5v in = 5v out.
Powercommander 3 usb, connect as YEC, see pp 3 for pinning, or purchase item 405, plug and play for PC3.

Powercommander 3 USB

Use plug and play item 405 or look at section above and at wiring diagram on pp 4.

Powercommander 5, PC5

Connect white and yellow to PC5 quickshifter port, use item 405 with the white connector removed. Change GP SG to t2, commonly closed loop, see below.

To set closed or open loop signal (t1 or t2), default at delivery is commonly open loop. Hold **left** button and then depress both buttons and hold for 10 sec, **t1** will show; continue to hold until **t2** shows, release both buttons, now the GP SG will have a commonly closed circuit

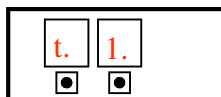

t1. Commonly open circuit. Used by 95% of quickshifter on the market. Default setting.

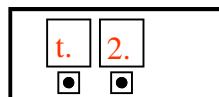

t2. Commonly open circuit. Used by only 5% of quickshifter on the market, PC5.

Honda HRC, (Dyna 2000) kill time adjustable 1.4.

For HRC 600 produced after 2008 use item 410, plug and play with QS connector under fuel tank, under left frame rail.

For HRC 600 produced before 2008, item 410 hardwired to the pass light switch connector. For HRC 1000 all year models, item 410 hardwired to the horn button connector. Purchase an item 304 connector to wire it to the bike.

To set a killtime, default at delivery is 65ms.

Hold **left** button and then depress both buttons and hold for 10 sec, **t1** will show, then **t2**; continue to hold until **65 shows**, release both buttons and toggle up or down to set a killtime, hold both buttons until value stops flashing and display goes black, killtime is set. Killtime is adjustable 10-99ms, **df** is 150ms and that should be used to return the GP SG to std, i.e. if it is used together with any other ECU than HRC.

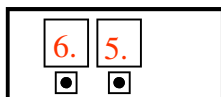

65ms, default setting. Adjustable 10-99ms.

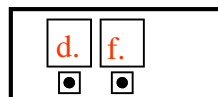

df. To restore std setting if unit is used together with any other ECU than HRC or Dyna.

Upgrade: All GP SG produced with firmware 1.4 and later can be upgraded to 1.4. with killtime adjustability. Contact info@cordona.net and send your GP SG to Cordona.

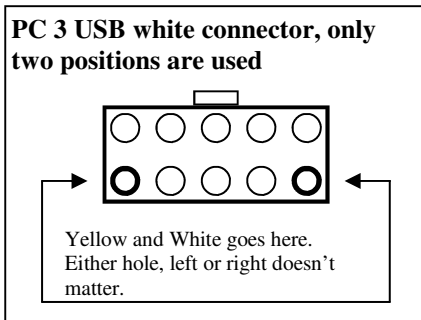
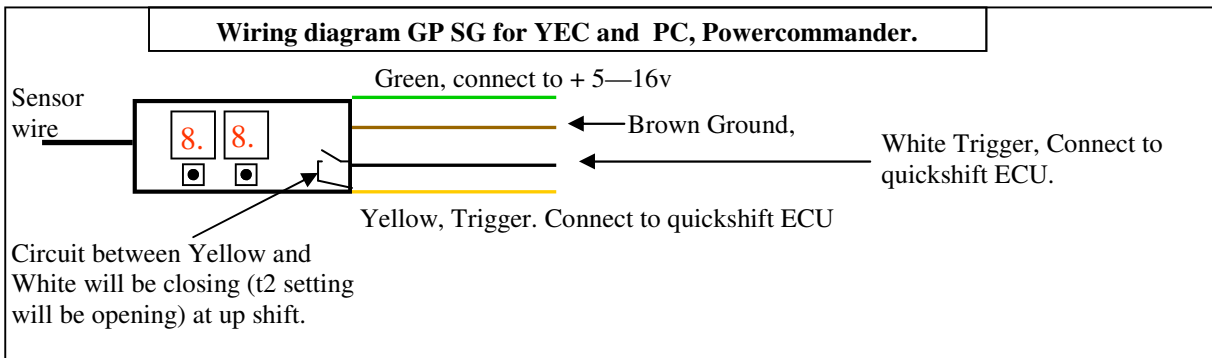
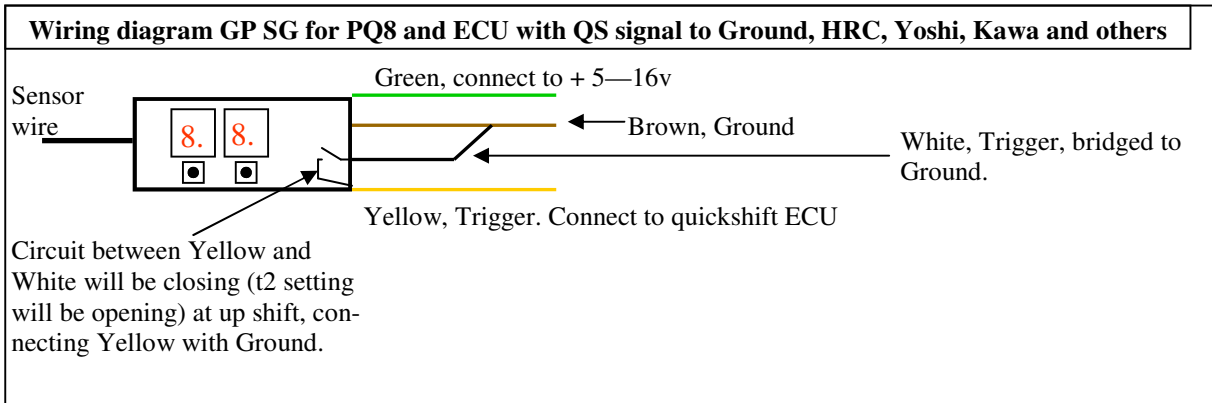

FAQ: My bike is shifting fine on the stand and while going slow but at high rpm it sometimes won't up shift?
Increase preload, vibrations at high rpm triggers GP SG continuously so when you try to up shift it is already activated. Check the bike's rear sets for play, excessive play can cause the GP SG to trigger at high rpm.
 If the sensor is located at the engine, move it to the rear sets, easy because the sensor has Magic Threads.
 If the sensor is located at the rear sets, move it to the engine.
 Also, try to rotate the sensor 90 degrees by loosening the nuts, sensor is activated by bending so rotating it 90 degrees will make it stiffer or weaker in the direction vibrations are bending it.

The Panel is showing E.1 when I power up the GP SG?
 The sensor is damaged and has a broken internal lead or the sensor wire is damaged. Replacement of sensor is needed, available as a spare part from a Cordona dealer, comes with a waterproof connector since the sensor wire needs to be cut at installation. Could also be a fault in sensor circuitry inside display unit.